

# GIDEONS ELITE BOYS CENTRE OF EXCELLENCE DECEMBER SELF-ASSESSMENT EXAMINATIONS

FORM TWO  
MATHEMATICS -FORM TWO- TERM 2  
121/1- Paper 1

**121/1**

**Mathematics (Alt. A)**

**Paper 1**

**Time: 2½ Hours**

**Name:** ..... **Adm No:** ..... **Class:** .....

**School:**..... **Date:** ..... **Sign:** .....

**Instructions to Candidates**

- (a) Write your name and admission number in the spaces provided at the top of this page.
- (b) Write your school name, sign and write the date of the examination in the spaces provided above.
- (c) This paper consists of **Two** sections: **Section I** and **Section II**
- (d) Answer **ALL** questions in Section I and **any five questions** from Section II
- (e) Show all the steps in your calculations, giving your answers at each stage in the spaces provided below each question.
- (f) Marks may be given for correct working even if the answer is wrong.
- (g) Non-Programmable silent electronic calculators and KNEC Mathematical Tables may be used.
- (h) This paper consists of **15** printed pages.
- (i) Candidates should check the question paper to ensure that all the pages are printed as indicated and no questions are missing.
- (j) Candidates should answer the questions in English.

**For Official Use Only**

**Section I**

1	2	3	4	5	6	7	8	9	10	11	12	13	14	15	16	Total

**Section II**

**Grand Total**

17	18	19	20	21	22	23	24	Total

**SECTION I – 50 Marks**

Answer *all* the questions in this section

1. Simplify without using calculators  $\frac{2}{5}$  of  $1\frac{2}{3} - \frac{1}{2} \sqrt{\frac{1\frac{2}{3} - 2\frac{1}{2}}{\frac{1}{3} - \frac{19}{27}}} + \frac{2}{3}$  (3 marks)

2. Find the perimeter of the figure ABCD given that BCD is a semicircle with DB as its diameter and the arc AD is a part of a circle whose centre is at point B. (Take  $\pi = \frac{22}{7}$ ) (3 marks)

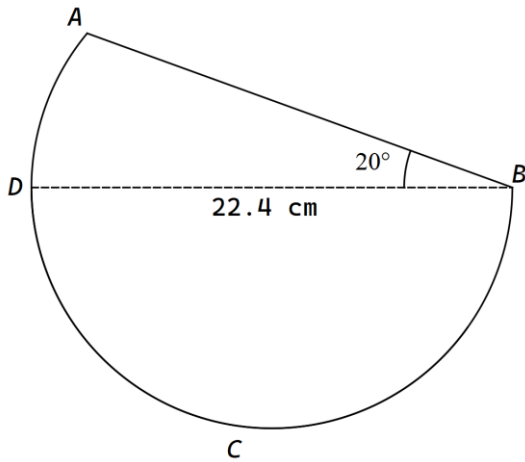

3. One interior angle of an irregular polygon is 800 and each of the other interior angles is 1250. Find the number of sides of the polygon. (3 marks)

4. Given that  $\cos \theta = 0.8$  , without using a mathematical table or a calculator find the value of  $\tan(90 - \theta)$  .  
(3 marks)

5. The wall of a bathroom has its length equal to its width. The wall is to be fitted with a number of whole rectangular tiles of dimensions 0.6 m by 0.48 m. Calculate the least dimension of the wall that can be covered by such tiles.  
(3 marks)

6. Use logarithm tables to evaluate:  $\sqrt{\frac{2.913 \times 0.0765}{38.74}}$  (4 marks)

7. The figure below shows the shape of a flower garden accurately drawn to scale of 1:1000.

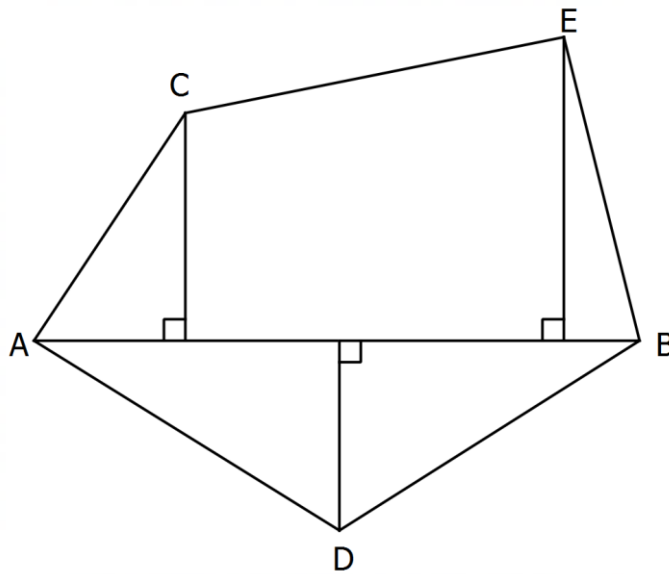

(a) Find the area of the garden, in hectares.

(3 marks)

(b) Taking AB as the base line, record the actual measurements of the garden as they would appear in a surveyor's field book

(1 mark)

8. Solve for  $x$  in the equation;  $9^{x+1} + 3^{2x+1} = 36$

(3 marks)

9. Juma left his home at the time show in the clock below.



He drove a distance of 140 km and arrived at his aunt's home at 10.15 a.m. Determine the average speed, in km/h, for Juma's journey. (3 marks)

10. Use tables of cubes, reciprocal and square roots only to evaluate  $26.52^3 - \frac{10}{\sqrt{0.0256}}$ . (4 marks)

11. Simplify  $\frac{2a^2 - b(5a + 12b)}{5ab^2 + 12b^3 - 2a^2b}$  (3 marks)

12. Show that the number 26753298 is divisible by both 6 and 11.

(3 marks)

13. When a shopkeeper sells an appliance to a customer at Ksh. 15000, he makes a loss of 4% on the cost price. What percentage profit would he have made by selling the appliance for Ksh. 18000? (3 marks)

14. Two containers have base area of  $900 \text{ cm}^2$  and  $144 \text{ cm}^2$  respectively. Calculate the capacity of the larger container in litres given that the volume of the smaller container is  $200 \text{ cm}^3$ . (3 marks)

15. The diagram below shows an accurate net of a solid VABC.

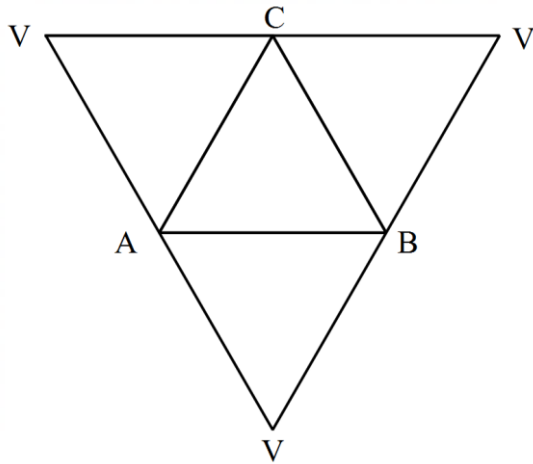

Describe the solid VABC.

(2 marks)

16. Mary has a driver, a gardener and a house manager. The driver's daily wage is three times that of the gardener. That of the gardener is Ksh.500 less than that of the house manager. Their total daily earnings are Ksh. 5500. Express the ratio of their earnings; driver: house manager: gardener in its simplest form.

(2 marks)

**SECTION II (50 Marks)**

*Answer any five questions in this section*

17. The figure below shows a solid rectangular based frustum whose vertical height is 20 cm.

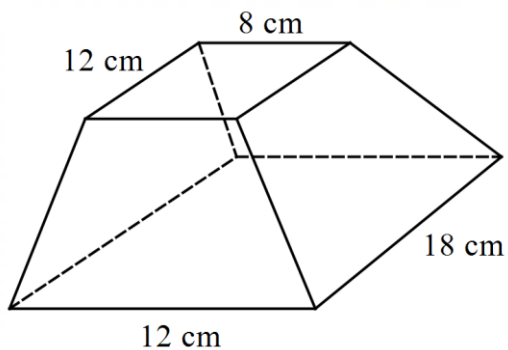

(a) Find the height of the original pyramid for which the frustum was obtained. (2 marks)

(b) Calculate the volume of the frustum. (3 marks)

(c) The frustum is recast into a composite solid comprising of a cone mounted on a hemispherical bottom of diameter 16.8 cm. Calculate the height of the composite solid. Use  $\pi = \frac{22}{7}$ . (5 marks)

18. Jackie is a sales executive earning a basic salary of Ksh. 20000 and a commission of 8% for the sales in excess of Ksh. 100000. If in April, she earned a total of Ksh.48000 in salaries and commissions.
- (a) Determine the amount of sales she made in that month (3 marks)
- (b) If the total sales in the month of May and June increased by 18% and then dropped by 25% respectively. Calculate
- (i) Jane's commission in the month of May (3 marks)
- (ii) Her total earning in the month of June. (4 marks)

19. Three traders Rehema, Lucie and Milly decided to buy a canter truck. The marked price of the truck was Ksh. 2800000. They could pay a deposit of 60% of the money and the rest to be paid within one year. Rehema, Lucie and Milly raised the deposit in the ratio 3:7:4 respectively. The balance was to be paid from the proceeds of the truck in the same ratio as the deposits. During the year, the truck realized Ksh. 2030000, which was shared in the same ratio as the deposits.

(a) How much deposit did each person contribute? (4 marks)

(b) How much of the remaining amount did Milly pay at the end of the year? (2 marks)

(c) After paying the remaining amount at the end of the year, how much money was Rehema left with? (4 marks)

20. Zeraki School English Club intends to buy a number of scrabble boards for Ksh. 16200. The supplier agreed to offer a discount of Ksh. 60 per scrabble board which enabled the club to get three more scrabble boards. By letting  $b$  as the original number of scrabble boards to be bought,

(a) Write an expression in terms of  $b$  for:

(i) the original price per scrabble board.

(1 mark)

(ii) the price per scrabble board after the discount.

(1 mark)

(b) Determine:

(i) the number of scrabble boards that the club originally intended to buy.

(4 marks)

(ii) the price per scrabble board after the discount

(1 mark)

(iii) the amount of money the club would have saved per scrabble board if they got the intended number of chess boards at a discount of 15%.

(3 marks)

21. The figure below shows two equal circles with radius 7 cm each with centres X and Y. The two circles are in contact at Q.

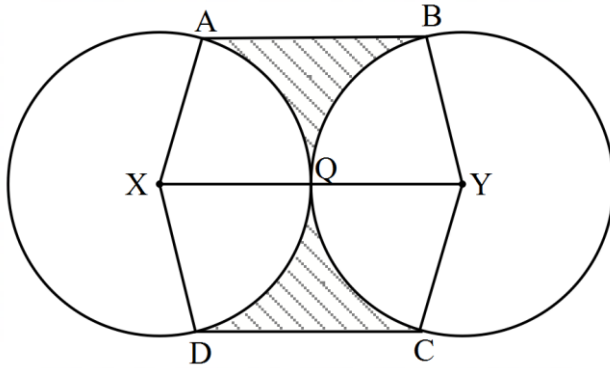

Given that  $\angle AXD = \angle BYC = 120^\circ$ , and lines AB, XQY and DC are parallel,  
Calculate the area of:

(a) the minor sector XAQD (2 marks)

(b) the area of the trapezium XABY (4 marks)

(c) the shaded region. (4 marks)

22. Triangle  $PQR$  whose vertices are  $P(0, 0)$ ,  $Q(0, 6)$  and  $R(2, 4)$  undergoes a transformation  $\mathbf{M}$  to produce triangle  $P'Q'R'$  with vertices  $P'(3, -1)$ ,  $Q'(4, 1)$  and  $R'(3, 2)$

(a) On the grid provided, plot and draw triangles  $PQR$  and  $P'Q'R'$ . (2 marks)

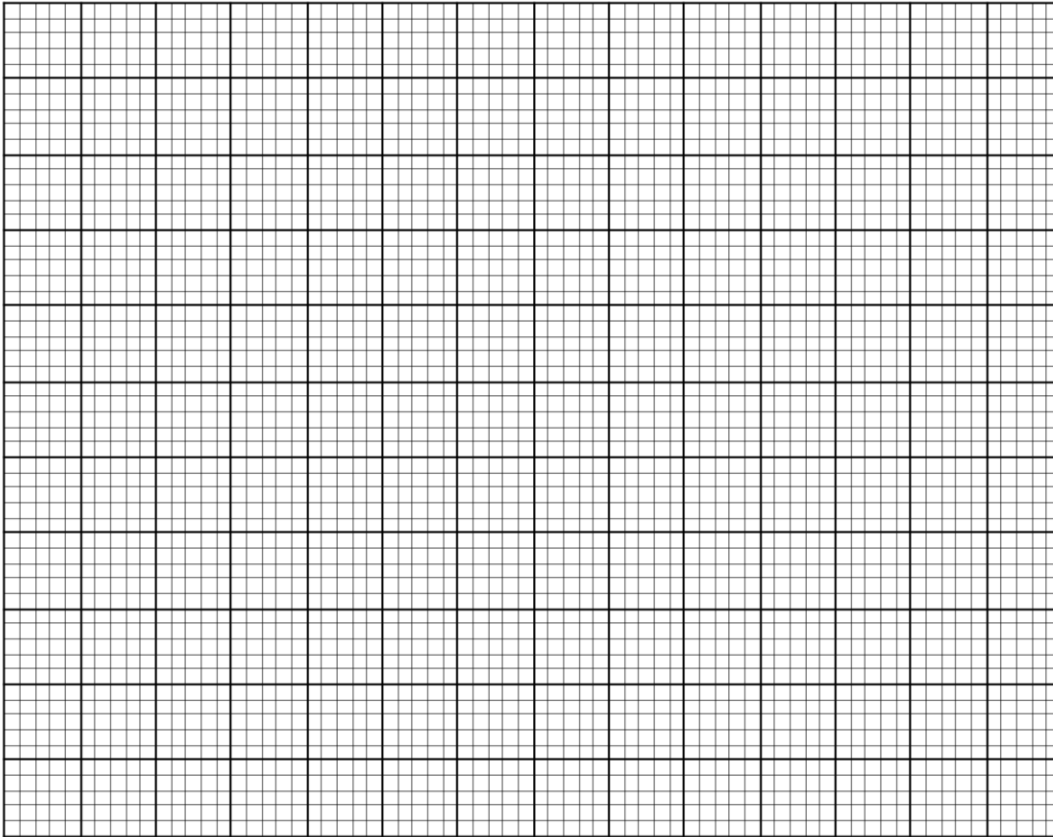

(b) Describe  $\mathbf{M}$  fully. (2 marks)

(c) Triangle  $P''Q''R''$  is the image of  $P'Q'R'$  under a rotation of  $+90^\circ$  about  $P$

(i) On the same grid, draw triangle  $P''Q''R''$  (2 marks)

(ii) State the coordinates of  $P''Q''R''$ . (1 mark)

(d) Triangle  $P''Q''R''$  undergoes a reflection along the line  $y+x=0$  to give triangle  $P'''Q'''R'''$ . On the same axes, draw triangle  $P'''Q'''R'''$ . (2 marks)

(e) Identify the type of congruency between triangles  $P''Q''R''$  and  $P'''Q'''R'''$ . (1 mark)

23. The diagram below shows part of a ranch enclosed by the boundaries AB, BC, CD and DA whose corners are at the points A, B, C and D

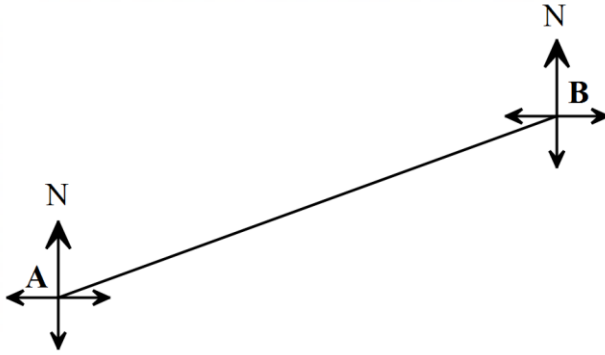

- (a) Given that the boundary AB is given as 70 km,
- (i) Determine the ratio used in drawing the boundary AB. (2 marks)
- (ii) Describe the location of point B with reference to point A. (2 marks)
- (b) If point D is on a bearing of  $130^{\circ}$  from A at a distance of 55 km, while point C is on a compass bearing of  $S40^{\circ}E$  from B, and due east of D, use the scale in part (a) (i) to show the boundaries BC, CD and AD. (3 marks)
- (c) Find;
- (i) the distance of point C from D. (2 marks)
- (ii) the bearing of D from B. (1 mark)

24. Line B whose equation is  $4x + 3y - 12 = 0$  is parallel to another line C which passes through the point  $(-7, 4)$

(a) Find the equation of C in the form  $y = mx + c$ , where  $m$  and  $c$  are constants and hence state the coordinates of the  $y$ -intercept. (3 marks)

(b) Another line D is perpendicular to C and passes through the point  $(-5, -7)$ . Find the equation of D in the form  $ax + by = c$ , where  $a$ ,  $b$  and  $c$  are integers. (3 marks)

(c) Find the coordinates of the point of intersection of the lines C and D. (4 marks)